

A

B

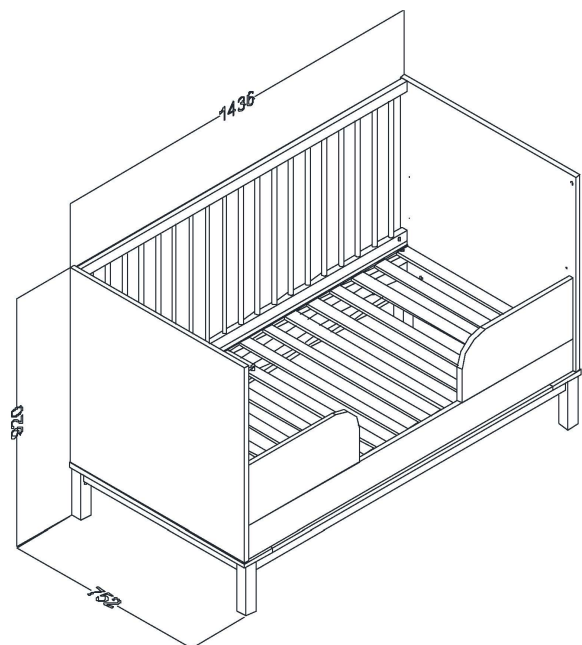

FR

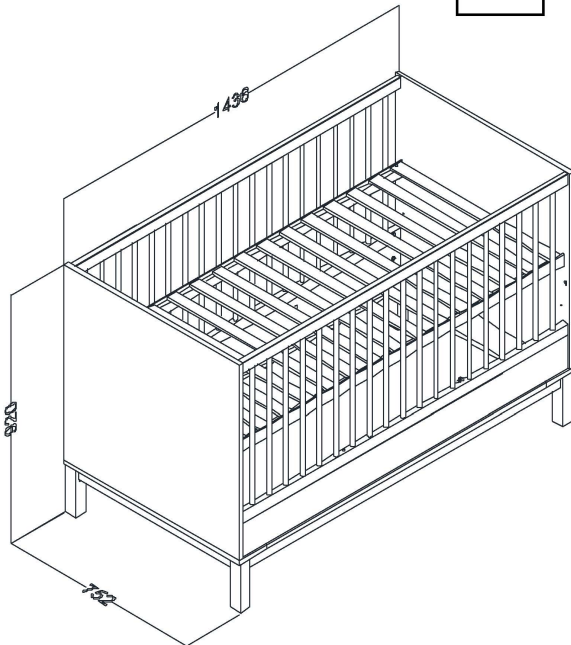

- Contrôler le contenu de votre colis avant de procéder au montage
- Ne détériorez pas l'emballage, il vous sera très utile pour protéger les éléments des coups et rayures pendant le montage
- Assemblez ensuite le meuble en suivant l'ordre défini par la numérotation
- Du fait de son confinement dans le carton après emballage, il est possible qu'au déballage et au montage votre produit dégage dans l'air des odeurs de vernis, plus ou moins prononcées. Ce dégagement est normal, il correspond à la fin de la maturation de la finition de votre produit. Afin que ces odeurs ne vous incommode pas, nous vous conseillons de disposer votre produit dans une pièce convenablement et régulièrement aérée, en ouvrant complètement les portes et en déposant les tiroirs à côté du meuble, jusqu'à disparition de ces odeurs.

EN



- Check the contents of your parcel before assembling
- Do not throw away the packing which could be very useful to protect the components from knocks and scratches when assembling
- Next assemble the article following the order of the numbers indicated
- You may notice a smell of varnish when you unpack your item, due to its having been stored in a box since its packaging. This smell can sometimes be quite strong. This is entirely normal, and is simply the result of the final stage in the maturing of the cabinet's finish. In order to avoid any inconvenience that may be caused by such odours, we recommend that you place the item in a well ventilated room, opening all doors, and removing the drawers from the cabinet, until any such odours have dissipated.

PT



- Confira o conteúdo da sua encomenda antes de iniciar a montagem
- Não danifique a embalagem, poderá ser-lhe útil para proteger os elementos de golpes ou riscos durante a montagem
- Proceda à montagem do móvel seguindo a ordem definida pela numeração
- Devido ao seu encerramento na caixa de cartão após o acondicionamento, é possível que, no momento da desembalagem e montagem do produto, este lance para o ar um cheiro a verniz, mais ou menos intenso. Esta é uma situação normal, que corresponde ao final da maturação do acabamento do seu produto. Para que este cheiro não o incomode, aconselhamos-lhe a colocar o produto num compartimento adequado e regularmente arejado, deixando as portas totalmente abertas e colocando as gavetas ao lado do móvel, até que o referido cheiro desapareça.

ES



- Controlar el contenido de su embalaje antes de proceder al montaje
- No deteriorar el paquete, que le será muy útil para proteger los elementos de golpes y rozaduras durante el montaje
- Acoplar de seguida el mueble, siguiendo la orden definida por la numeración
- Dado que el mueble ha permanecido encerrado en la caja de cartón desde el momento de su acondicionamiento, es posible que al desembalarlo desprenda a la atmósfera un olor a barniz más o menos pronunciado. Este olor es normal y corresponde a la etapa final de la maduración del acabado del producto que adquirió. Con el fin de evitar que esos olores sean para usted una incomodidad, le aconsejamos dejar el producto en un lugar adecuado y regularmente aireado; abrir por completo las puertas, retirar los cajones y dejarlos aireándose junto al mueble, hasta que tales olores hayan desaparecido.

DE



- Vor Montage den Inhalt Ihres Paekchens kontrollieren
- Die Verpackung nicht zerstören, sie wird Ihnen nützlich sein, um die Teile bei der Montage vor Stößen und Kratzern zu schützen.
- Das Möbel dann in der Reihenfolge der Nummerierung zusammenbauen
- Da das Möbelstück eine gewisse Zeit lang eng verpackt war, ist nicht auszuschließen, dass sich beim Auspacken und der Montage ein mehr oder minder starker Lackgeruch entwickelt. Diese Geruchsentwicklung nach der Endbearbeitung ist durchaus normal. Damit der Lackgeruch Sie nicht stört, empfehlen wir Ihnen, Ihren Einrichtungsgegenstand in einen gut und regelmäßig gelüfteten Raum zu stellen, die Schubladen herauszunehmen und die Türen ganz zu öffnen, bis sich der Lackgeruch vollständig verflüchtigt hat.

IT



- Verificare il contenuto della confezione prima del montaggio
- Non eliminare l'imballo che potrà essere utilizzato per proteggere il prodotto dai danni durante il montaggio
- Montare l'articolo seguendo l'ordine di numerazione
- Per il fatto di essere rimasto chiuso nel cartone dopo l'imballaggio, è possibile che il mobile una volta liberato dal cartone e durante il montaggio sprigioni nell'aria odori di vernice più o meno forti. E' un fatto assolutamente normale, e indica la fine della maturazione della finitura del prodotto. Affinché questi odori non Le creino fastidio, raccomandiamo di collocare il prodotto in un locale adeguatamente e regolarmente aerato, aprendo completamente le porte e depositando i cassetti accanto al mobile fino alla scomparsa degli odori.

NL



- De inhoud van uw pakket controleren alvorens met de montage te beginnen
- De verpakking niet beschadigen, deze kan heel handig zijn om de onderdelen te beschermen tegen schokken en krassen tijdens de montage
- Zet vervolgens het meubel in elkaar in de volgorde die is bepaald in de nummering
- Het is mogelijk dat zich bij het uitpakken en in elkaar zetten van uw product een min of meer uitgesproken laklucht verspreidt. Dit komt omdat het product na het inpakken in de doos heeft gezeten. Het is normaal dat dit gebeurt, het hoort bij de uiteindelijke afwerking van uw product. Om te voorkomen dat u last heeft van deze lucht, raden we u aan om uw product in een voldoende en regelmatig geventileerde ruimte neer te zetten. Doe daarbij de deurtjes helemaal open en zet de laden naast het meubel neer totdat deze lucht is verdwenen.

**Fabriqu  en Hungary
 made in Hungary
 fabricado na Hungary
 fabricado en Hungary
 Hergestellt in Hungary
 fabbricato in Hungary
 Geproduceerd in Hungary**

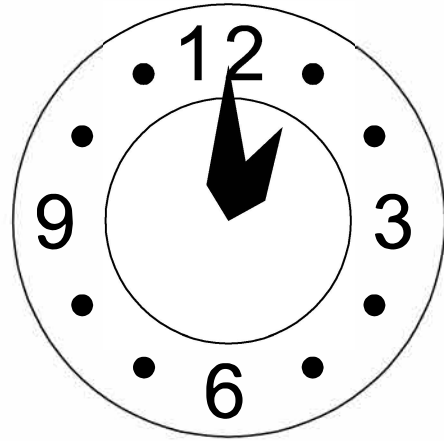
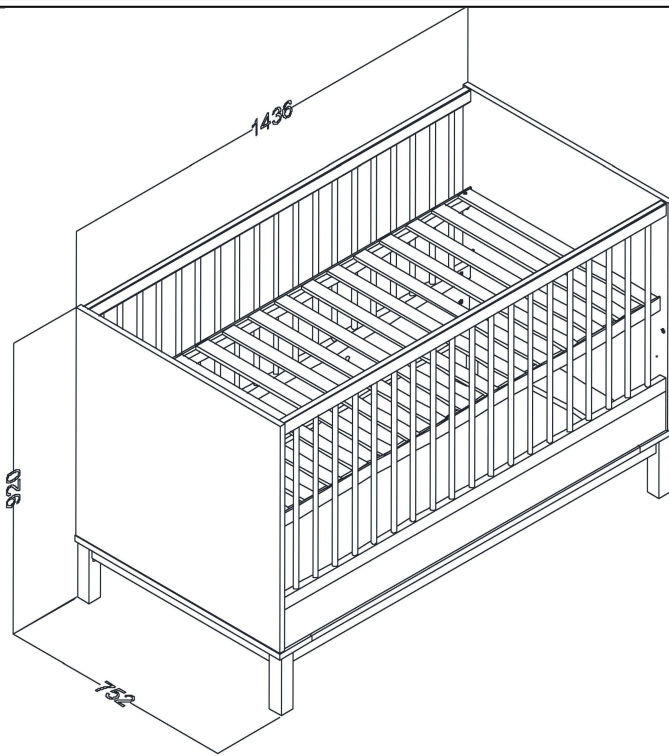

60 min

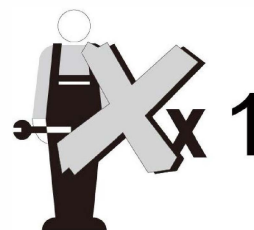
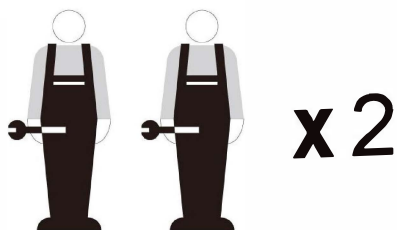
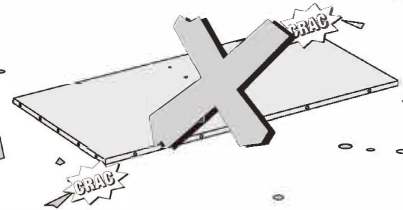
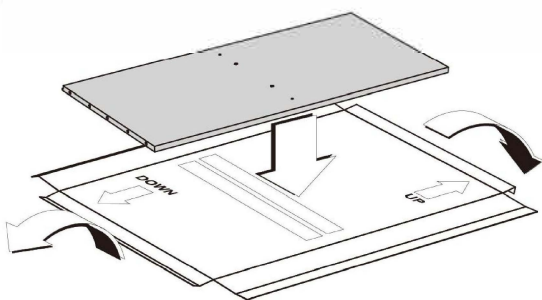
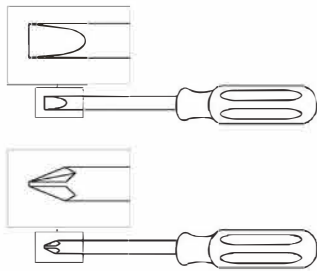

FR – IMPORTANT! A CONSERVER POUR CONSULTATION ULTERIEURE: LIRE ATTENTIVEMENT

- A monter par un adulte. Un adulte doit vérifier le bon assemblage avant l'emploi
- Attention! tenir les vis et petits éléments et sachets hors de portée des enfants
- Bien identifier les éléments avant de commencer le montage
- Ne pas utiliser le lit si une partie est cassée, endommagée ou manquante
- En cas de problème contactez notre service après-vente
- Toujours suivre les instructions du fabricant
- Ne pas placer le lit proche d'une source de chaleur, d'une fenêtre ou d'autre meuble
- Ne pas sauter sur le lit
- Entretien: nettoyer avec un chiffon doux et sec. En cas de taches plus grosses, frottez soigneusement avec une éponge légèrement humide et non abrasive

EN – IMPORTANT! KEEP FOR FUTURE REFERENCE: READ CAREFULLY

- To be assembled by an adult. Assembly must be checked by an adult before use
- Warning ! keep all screws, small parts and plastic bags out of the reach of children
- Properly identify all parts before assembling
- Do not use the bed if a part is broken, damaged or missing
- Should any problems arise, please contact our After Sales Service
- Manufacturer's instructions shall be followed at all times
- Do not place the bed close to a source of heat, a window or another piece of furniture
- Do not jump on the bed
- Care: clean with a soft, dry cloth. In case of larger stains, carefully rub with a slightly damp, non-abrasive sponge

PT – IMPORTANTE! GARDE PARA CONSULTA POSTERIOR: LER ESTAS INSTRUÇÕES CUIDADOSAMENTE

- A ser montado por um adulto. Um adulto deve verificar a boa montagem antes da utilização
- Atenção! mantenha os parafusos, acessórios pequenos e saco de plástico fora do alcance das crianças
- Identifique bem os acessórios antes de começar a montagem
- Não utilize a cama se um elemento estiver partido, danificado ou em falta
- Para qualquer esclarecimento, contacte os nossos serviços através do telefone
- As instruções do fabricante devem ser sempre cumpridas
- Não coloque a cama perto de uma fonte de calor, uma janela ou outro móvel
- Não salte na cama
- Manutenção: limpe com um pano macio e seco. Em caso de manchas maiores, esfregue cuidadosamente com uma esponja ligeiramente húmida e não abrasiva

ES – IMPORTANTE! CONSERVAR PARA FUTURAS CONSULTAS: LEER DETENIDAMENTE

- A montar por un adulto. Un adulto debe comprobar el buen montaje antes de la utilización
- ¡Advertencia! mantener los tornillos, los pequeños elementos y bolsitas fuera del alcance de los niños
- Identificar debidamente los elementos antes de empezar el montaje
- No use la cuna si alguna pieza está rota o dañada, o si falta alguna pieza
- Si tiene problemas, contactar nuestro servicio postventa
- Deben seguirse siempre las instrucciones del fabricante
- No coloque la cuna cerca de una fuente de calor, de una ventana ni de otro mueble
- No saltar sobre la cama
- Cuidados: limpiar con un paño suave y seco. En caso de manchas grandes, frotar con cuidado utilizando una esponja húmeda no abrasiva

DE – WICHTIG! FÜR SPÄTERE BEZUGNAHME AUFBEWAHREN: SORGFÄLTIG LESEN

- Von einem Erwachsenen zu montieren. Die korrekte Montage muss vor Gebrauch von einem Erwachsenen geprüft werden
- Achtung! die Schrauben und kleinen Teile ausserhalb der Reichweite von Kindern lagern
- Vor Montagebeginn alle Teile identifizieren
- Das Bett nicht benutzen, wenn ein Teil gebrochen oder beschädigt ist oder fehlt
- Im Problemfall Ihren Kundendienst anrufen
- Stets die Herstelleranweisungen beachten
- Das Bett nicht in der Nähe einer Wärmequelle, eines Fensters oder eines anderen Möbelstücks aufstellen
- Nicht auf dem Bett springen
- Wartung: Mit einem weichen, trockenen Tuch reinigen. Bei größeren Flecken vorsichtig mit einem leicht feuchten, nicht scheuernden Schwamm abreiben

IT - IMPORTANTE! CONSERVARE QUESTE INFORMAZIONI PER ULTERIORI CONSULTAZIONI: LEGGI ATTENTAMENTE

- Il montaggio deve essere eseguito da un adulto. Un adulto dovrà verificare il corretto montaggio prima dell'uso
- Avvertenza! tenere le viti ed i componenti di piccole dimensioni lontano dalla portata dei bambini
- Controllare i pezzi prima del montaggio
- Non utilizzare la culla se una parte è rotta, danneggiata o mancante
- In caso di necessità contattare il nostro servizio post-vendita
- Seguire sempre le istruzioni del costruttore
- Non mettere la culla vicino a una fonte di calore, a una finestra o a un altro mobile
- Non saltare sul letto
- Manutenzione: pulire con un panno morbido e asciutto. Per le macchine più grandi, strofinare accuratamente con una spugna leggermente umida e non abrasiva

NL - BELANGRIJK! BEWAAR VOOR LATERE RAADPLEGING: LEES AANDACHTIG

- Moet door een volwassene worden gemonteerd. Voor gebruik moet een volwassene controleren dat het product goed in elkaar is gezet
- Opgelet! schroeven en kleine elementen en zakjes buiten bereik van kinderen houden
- De elementen goed identificeren alvorens met de montage te beginnen
- Gebruik het bed niet als er een onderdeel gebroken of beschadigd is of als er een onderdeel ontbreekt
- Neem bij problemen contact op met onze klantenservice
- Volg altijd de instructies van de fabrikant
- Plaats het bed niet in de buurt van een warmtebron, een venster of een ander meubelstuk
- Niet springen op het bed
- Onderhoud: maak schoon met een zachte en droge doek. In geval van grotere vlekken, veeg voorzichtig schoon met een licht bevochtigde en niet-schurende spons

FR - IMPORTANT, A CONSERVER POUR CONSULTATION ULTERIEURE: A LIRE SOIGNEUSEMENT

- **AVERTISSEMENT:** Attention au danger de placer le lit à proximité de flammes nues et d'autres sources de forte chaleur, comme les appareils de chauffage électrique, les appareils de chauffage à gaz, etc.
- **AVERTISSEMENT:** Ne pas utiliser le lit si certains éléments sont cassés, endommagés ou manquants, et n'utiliser que des pièces détachées approuvées par le fabricant
- **AVERTISSEMENT:** Ne rien laisser dans le lit et ne pas le placer à côté d'un produit qui pourrait fournir une prise pour les pieds de l'enfant ou présenter un danger d'étouffement ou d'étranglement, par exemple des ficelles, des cordons de rideaux, etc.
- **AVERTISSEMENT:** Ne pas utiliser plus d'un matelas dans le lit

- La position la plus basse du sommier est la plus sûre
- Il convient que le sommier soit toujours utilisé dans la position la plus basse une fois le bébé en âge de s'asseoir
- L'épaisseur du matelas doit être telle que la hauteur intérieure (c'est-à-dire la distance de la surface du matelas à la partie supérieure du cadre du lit) soit d'au moins 500mm dans la position la plus basse du sommier et d'au moins 200mm dans la position la plus haute

- La marque figurant sur le lit indique l'épaisseur maximale du matelas à utiliser
- Tous les éléments de fixation doivent toujours être convenablement serrés et régulièrement vérifiés, et resserrés si nécessaire
- Afin de prévenir du risque de chute, le lit ne doit plus être utilisé lorsque l'enfant est capable d'en sortir seul (option A only)
- Taille du matelas à utiliser avec le lit: 140x 70 x 10 cm

EN - IMPORTANT, KEEP FOR FUTURE REFERENCE: READ CAREFULLY

- **WARNING:** Beware of the danger of placing the bed near open flames and other sources of intense heat, such as electric heaters, gas heaters, etc.
- **WARNING:** Do not use the cot if any part is broken, torn or missing and use only spare parts approved by the manufacturer
- **WARNING:** Do not leave anything in the cot or place the cot close to another product, which could provide a foothold or present a danger of suffocation or strangulation, e.g. strings, blind/curtain cords

- **WARNING:** Do not use more than one mattress in the cot.

- The lowest position of the cot base is the safest
- The cot base should always be used in the lowest as soon as the baby is old enough to sit up
- The thickness of the mattress shall be such that the internal height (surface of the mattress to the upper edge of the cot frame) is at least 500 mm in the lowest position of the cot base and at least 200 mm in the highest position of the cot base

- The mark on the coat indicates the maximum thickness of the mattress that can be used
- All assembly fittings should always be tightened properly and that fittings should be checked regularly and retightened as necessary
- To prevent injury from falls when the child is able to climb out of the cot, the cot shall no longer be used for that child (option A only)
- Size of the mattress to be used with the cot: 140x 70 x 10 cm

PT - IMPORTANTE, GARDE PARA CONSULTA POSTERIOR: LER ESTAS INSTRUÇÕES CUIDADOSAMENTE

- **AVISO:** Atenção ao perigo de colocar a cama próximo de chamas acesas e outras fontes de calor forte, como os aparelhos de aquecimento elétrico, os aparelhos de aquecimento a gás, etc.
- **AVISO:** Não use a cama se determinados elementos estiverem partidos, danificados ou em falta e use apenas peças sobresselentes aprovadas pelo fabricante
- **AVISO:** Não deixa nada na cama e não a coloque perto de um produto que possa fornecer um apoio para os pés da criança ou apresentar um perigo de asfixia ou de estrangulamento, por exemplo fios, cordões de cortinas, etc.
- **AVISO:** Não use mais de um colchão na cama

- A posição mais baixa da base do colchão é a mais segura
- É conveniente que a base do colchão seja sempre usada na posição mais baixa logo que o bebé tenha idade para se sentar
- A espessura do colchão deve ser tal que a altura interna (ou seja, a distância entre a superfície do colchão e a parte superior da estrutura da cama) seja de, pelo menos, 500 mm na posição mais baixa do colchão e de, pelo menos, 200 mm na posição mais alta
- A marca na cama indica a espessura máxima do colchão a utilizar
- Todos os elementos de fixação devem estar sempre bem apertados e ser verificados com regularidade, e reapertados se necessário
- Para prevenir o risco de queda, a cama já não deve ser usada se a criança for capaz de sair dela sozinha (apenas opção A).
- Dimensão do colchão a usar com a cama : 140x 70 x 10 cm

ES - IMPORTANTE, CONSERVAR PARA FUTURAS CONSULTAS: LEER DETENIDAMENTE

- **ADVERTENCIA:** Atención al peligro que acarrea colocar la cama cerca de llamas abiertas u otras fuentes de calor fuerte, como aparatos eléctricos de calefacción, estufas de gas, etc.
- **ADVERTENCIA:** No use la cuna si alguna pieza está dañada, desgastada o si falta alguna pieza, y utilice únicamente piezas de recambio aprobadas por el fabricante.
- **ADVERTENCIA:** No deje nada en la cuna y no coloque la cuna cerca de otro producto que pudiera servir de punto de apoyo o suponer un riesgo de asfixia o estrangulación, por ejemplo, cuerdas o cordeles de cortinas
- **ADVERTENCIA:** No use más de un colchón en la cuna.
- La posición más baja de la base de la cuna es la más segura.
- La base de la cuna debería usarse siempre en la posición más baja en cuanto el bebé tenga edad suficiente para sentarse.
- El grosor del colchón debe ser tal que la altura interna (desde la superficie del colchón hasta el borde superior del marco de la cuna) sea como mínimo 500 mm en la posición más baja de la base de la cuna, y como mínimo 200 mm en la posición más alta de la base de la cuna.
- La marca en la cuna indica el grosor máximo del colchón que se puede usar.
- Todos los elementos de montaje deben apretarse siempre correctamente, comprobarse regularmente y volver a apretarse en caso necesario.
- Para evitar lesiones por caídas, no debe seguir usándose la cuna con un niño cuando dicho niño es capaz de salir de la cuna (solo opción A).
- El tamaño del colchón a usar con la cuna: 140x 70 x 10 cm

DE - WICHTIG, FÜR SPÄTERE BEZUGNAHME AUFBEWAHREN: SORGFÄLTIG LESEN

- **WARNHINWEIS:** Achtung: Es ist gefährlich, das Bett in die Nähe offener Flammen und starker Hitzequellen, wie z. B. elektrische Heizgeräte, Gasheizungen usw., zu stellen.
- **WARNHINWEIS:** Das Bett nicht benutzen, wenn Teile gebrochen oder beschädigt sind oder fehlen. Nur die vom Hersteller zugelassenen Ersatzteile verwenden.
- **WARNHINWEIS:** Nichts im Bett liegenlassen und nichts neben das Bett stehen, das den den Füßen des Kindes Halt geben oder eine Erstickungs- oder Würgegefahr darstellen könnte, wie z. B. Schnüre, Vorhangschnüre usw.
- **WARNHINWEIS:** Nicht mehr als eine Matratze im Bett verwenden.
- Die unterste Position des Bettenbodens ist die sicherste Position.
- Der Bettenboden sollte immer in der untersten Position verwendet werden, sobald das Baby alt genug ist, um zu sitzen.
- Die Matratze muss so dick sein, dass die Innenhöhe (d. h. der Abstand von der Matratzenoberfläche bis zur Oberseite des Bettrahmens) in der untersten Position des Bettenbodens mindestens 500 mm und in der höchsten Position mindestens 200 mm beträgt.
- Die Markierung am Bett gibt die maximale Dicke der zu verwendenden Matratze an.
- Alle Befestigungselemente müssen stets ordnungsgemäß festgezogen und regelmäßig überprüft und gegebenenfalls nachgezogen werden.
- Um der Gefahr eines Sturzes vorzubeugen, sollte das Bett nicht mehr benutzt werden, wenn das Kind in der Lage ist, aus eigener Kraft herauszukommen (nur Option A).
- Matratzengröße zur Verwendung mit dem Bett: 140x 70 x 10cm

IT - IMPORTANTE, CONSERVARE QUESTE INFORMAZIONI PER ULTERIORI CONSULTAZIONI: LEGGI ATTENTAMENTE





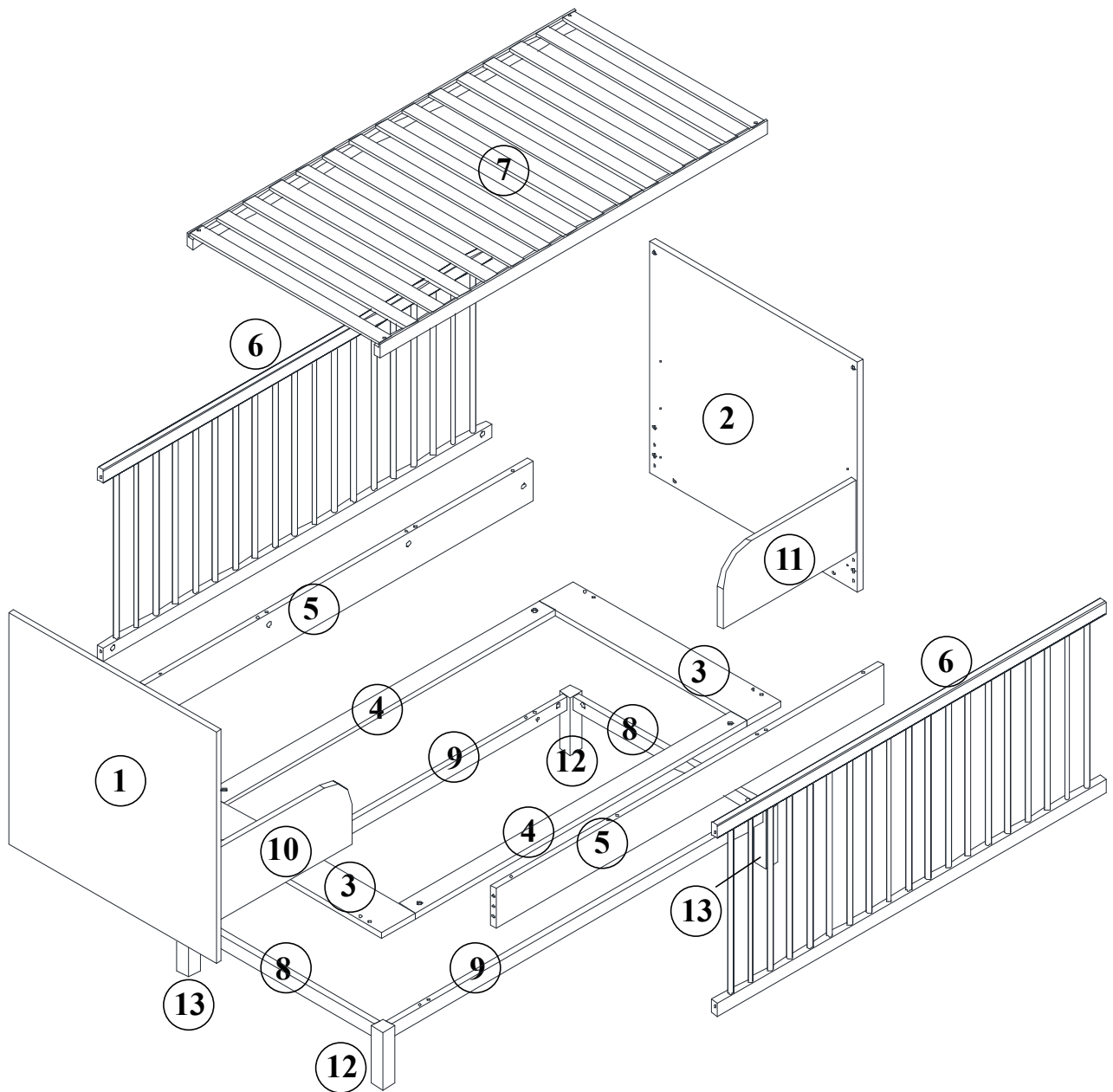

- **AVVERTENZA:** Fare attenzione a non collocare il letto vicino a fiamme libere e altre fonti di forte calore, come riscaldatori elettrici, riscaldatori a gas, ecc.
- **AVVERTENZA:** Non utilizzare la culla se alcuni elementi sono rotti, danneggiati o mancanti. Utilizzare solo parti di ricambio approvate dal costruttore
- **AVVERTENZA:** Non lasciare nella culla e non mettere accanto alla culla oggetti che potrebbero fornire un appiglio per i piedi del bambino o costituire un pericolo di soffocamento o strangolamento, ad esempio lacci, corde di tenda, ecc.
- **AVVERTENZA:** Non utilizzare più di un materasso nella culla
- La posizione più bassa della base della culla è anche la più sicura.
- La culla deve essere sempre utilizzata nella posizione più bassa dopo che il bebè ha raggiunto l'età per stare seduto.
- Lo spessore del materasso deve essere tale che l'altezza interna (vale a dire la distanza della superficie del materasso dalla parte superiore del telaio della culla) sia di almeno 500 mm nella posizione più bassa e di almeno 200 mm nella posizione più alta.
- Il marchio sulla culla indica lo spessore massimo del materasso utilizzabile.
- Tutti gli elementi di fissaggio devono essere sempre correttamente serrati e periodicamente controllati.
- Per evitare il rischio di caduta, non utilizzare la culla quando il bambino è in grado di uscire da solo dalla stessa (solo opzione A).
- Dimensioni del materasso da utilizzare: 140x 70 x 10 cm

NL - BELANGRIJK, BEWAAR VOOR LATERE RAADPLEGING: LEES AANDACHTIG

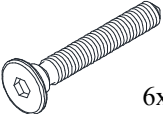
- **WAARSCHUWING:** Plaats het bed niet in de nabijheid van open vlammen of warmtebronnen, zoals elektrische verwarmingstoestellen, gaskachels, enz.
- **WAARSCHUWING:** Gebruik het bed niet als bepaalde onderdelen beschadigd zijn of ontbreken. Gebruik alleen onderdelen die door de fabrikant zijn goedgekeurd.
- **WAARSCHUWING:** Laat niets in het bed achter en plaats het bed niet naast een voorwerp waar er risico is op het vast komen te zitten van de voeten van het kind of gevaar op verstikking of verstrikking, bijv. touwen, gordijnkoorden, enz.
- **WAARSCHUWING:** Leg nooit meerdere matrassen in het bed.
- De laagste positie van de bedbodem is de meest veilige.
- Gebruik de bedbodem altijd in de laagste positie zodra de baby oud genoeg is om te zitten.
- De dikte van de matras moet voor een minimale interne hoogte (d.w.z. de afstand tussen het oppervlak van de matras en het bovenste deel van het bedframe) van minstens 500 mm zorgen in de laagste positie van de bedbodem en minstens 200 mm in de hoogste positie.
- Het teken op het bed geeft de maximale te gebruiken dikte van de matras aan.
- Alle bevestigingen moeten altijd juist zijn vastgemaakt, regelmatig worden gecontroleerd en, indien nodig, opnieuw worden vastgemaakt.
- Om risico op vallen te vermijden, gebruikt u het bed niet langer als het kind zelfstandig uit het bed kan klimmen (alleen optie A).
- Afmeting van de matras te gebruiken met het bed: 140x 70 x 10 cm

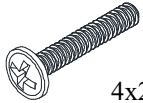
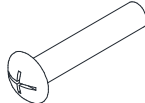
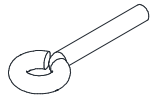
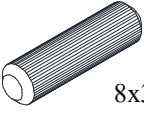
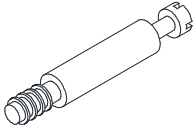

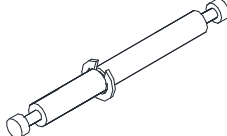
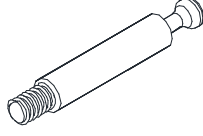
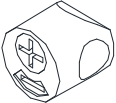
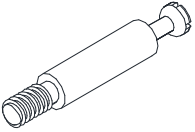

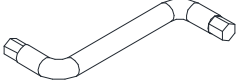
A X 8  6x40mm	B X 12 	C X 4  4x25mm	D X 4 	E X 4 
F X 38  8x30mm	G X 8 	H X 16 	K X 2 	L X 12 
M X 12 	N X 4 	O X 4  6x80mm	P X 1 	

1

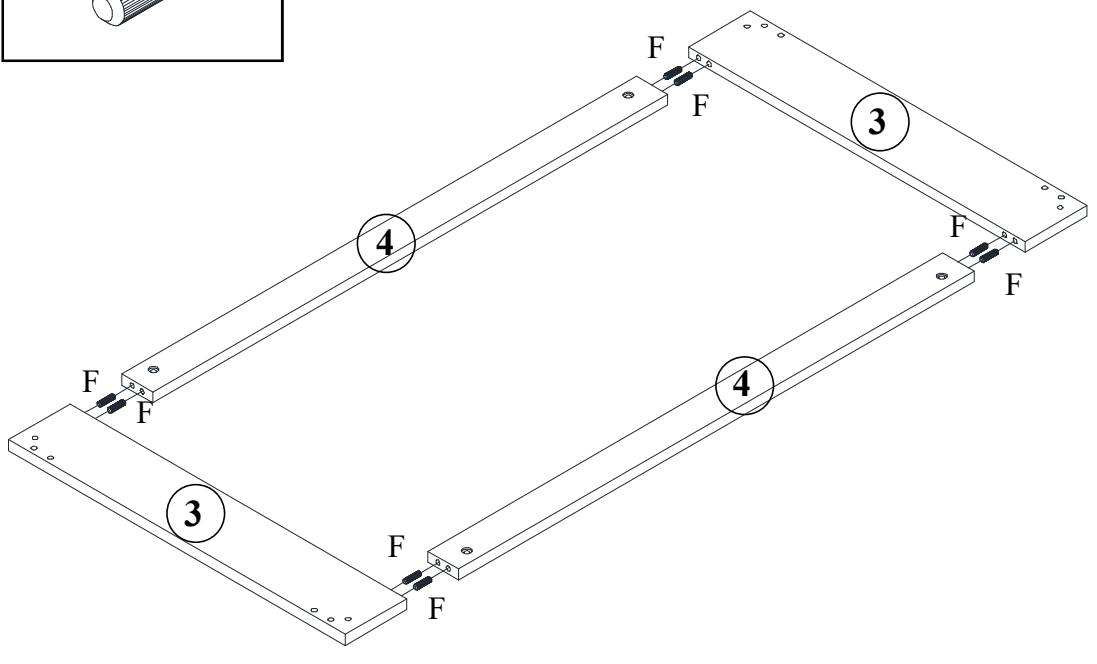
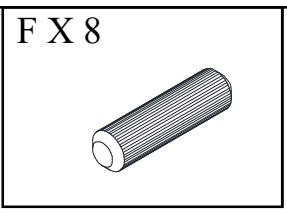

2

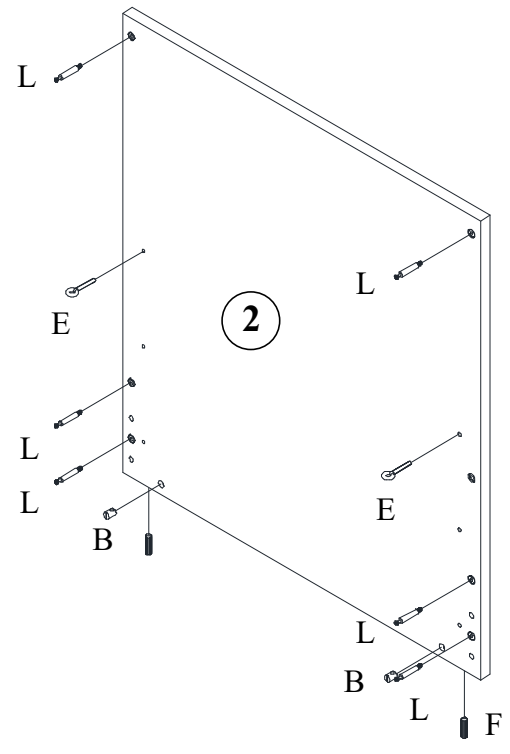
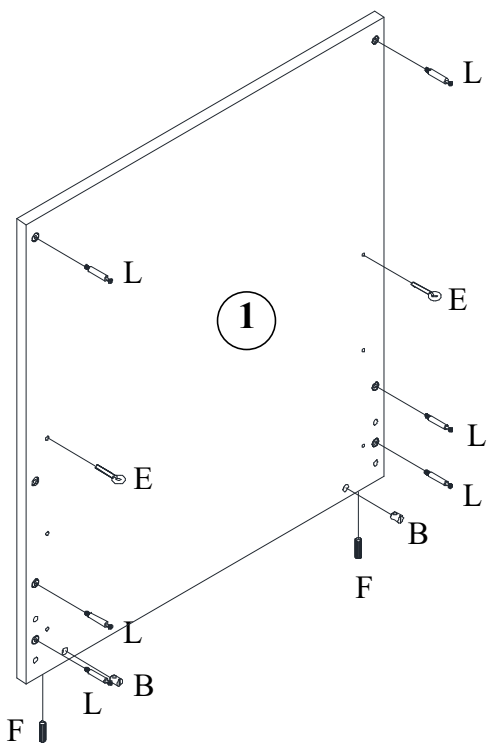
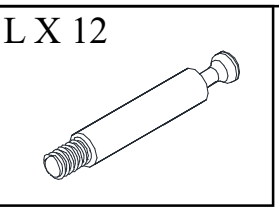
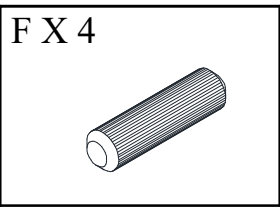
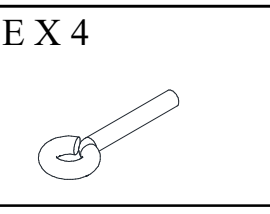
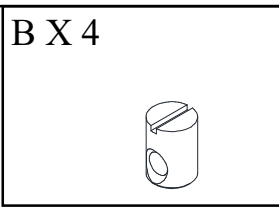

3

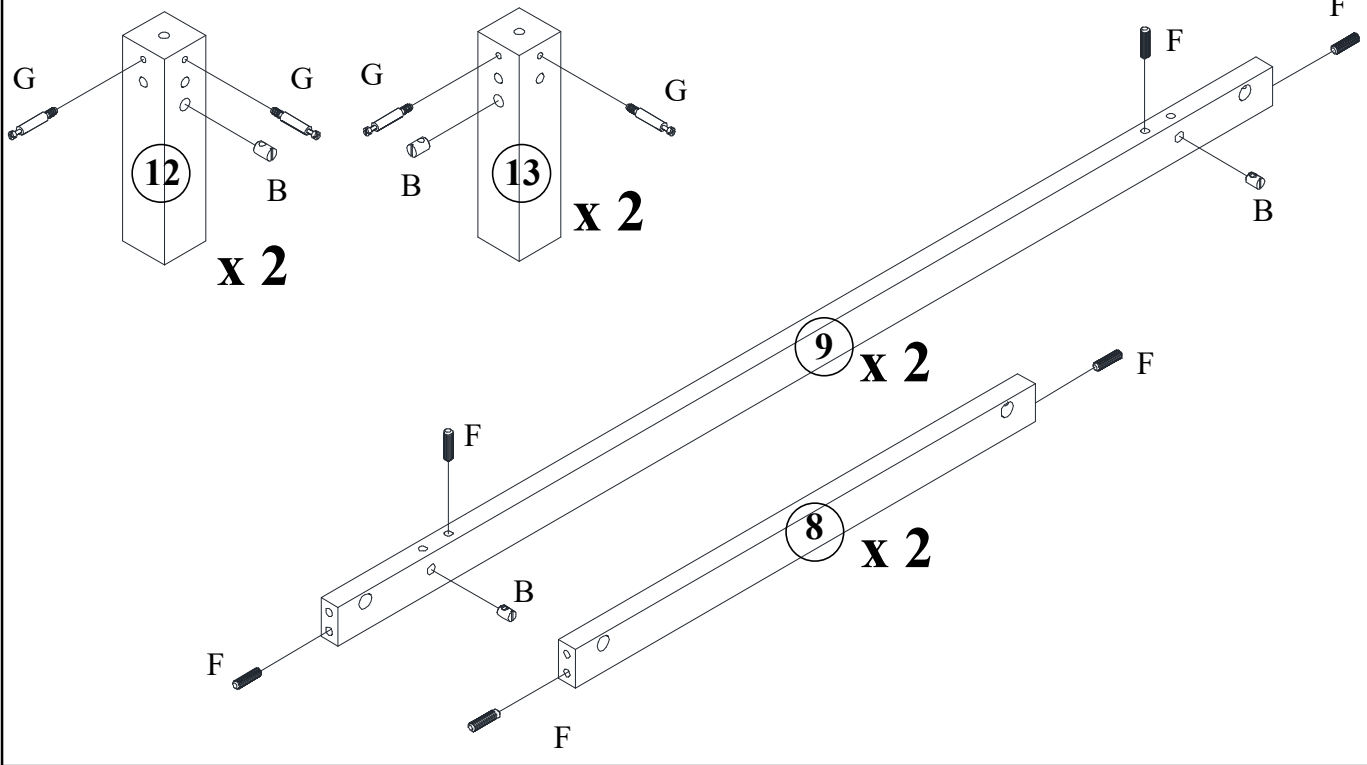
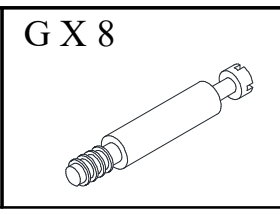
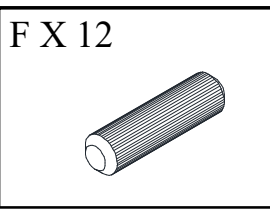
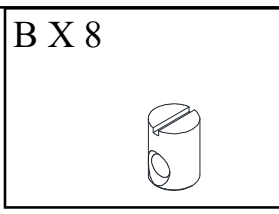

4

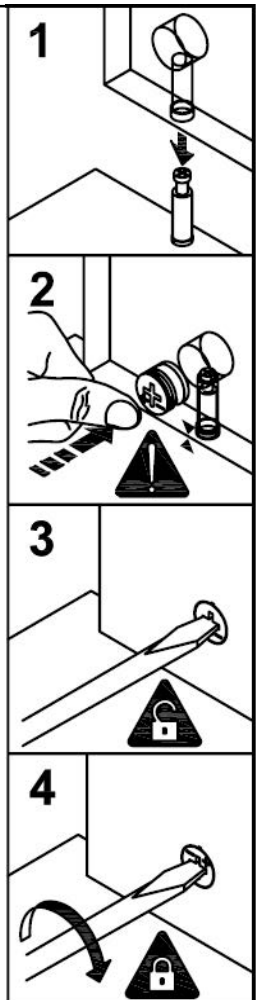
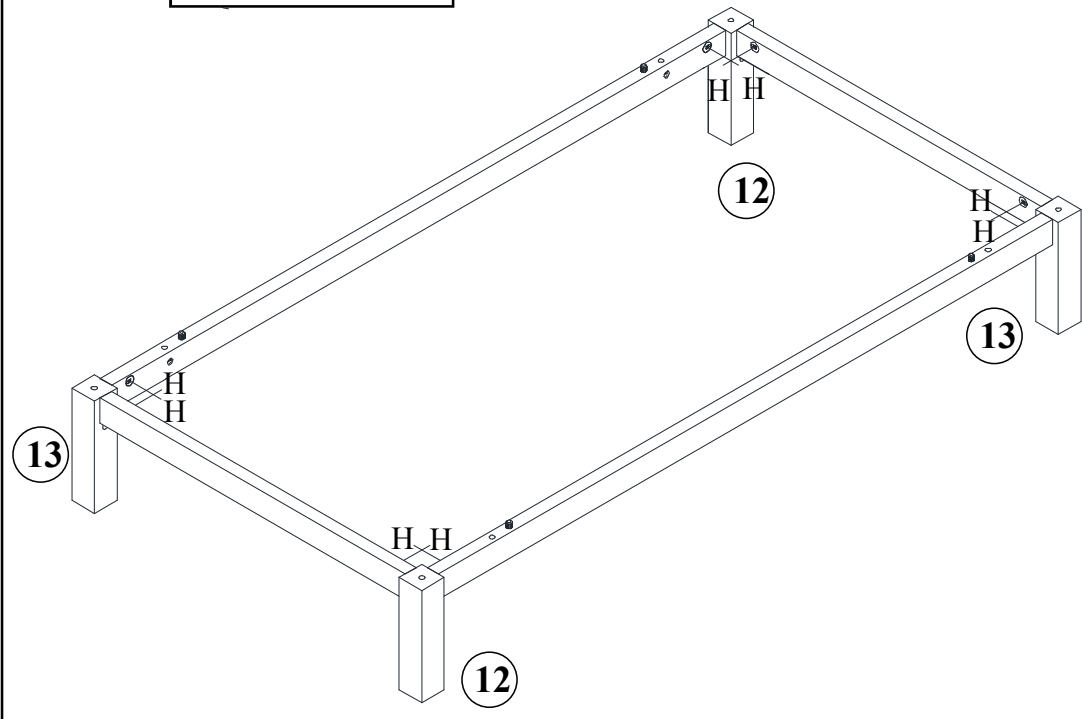
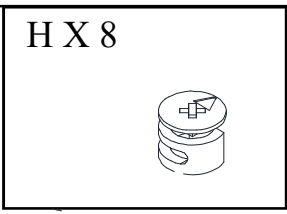

5

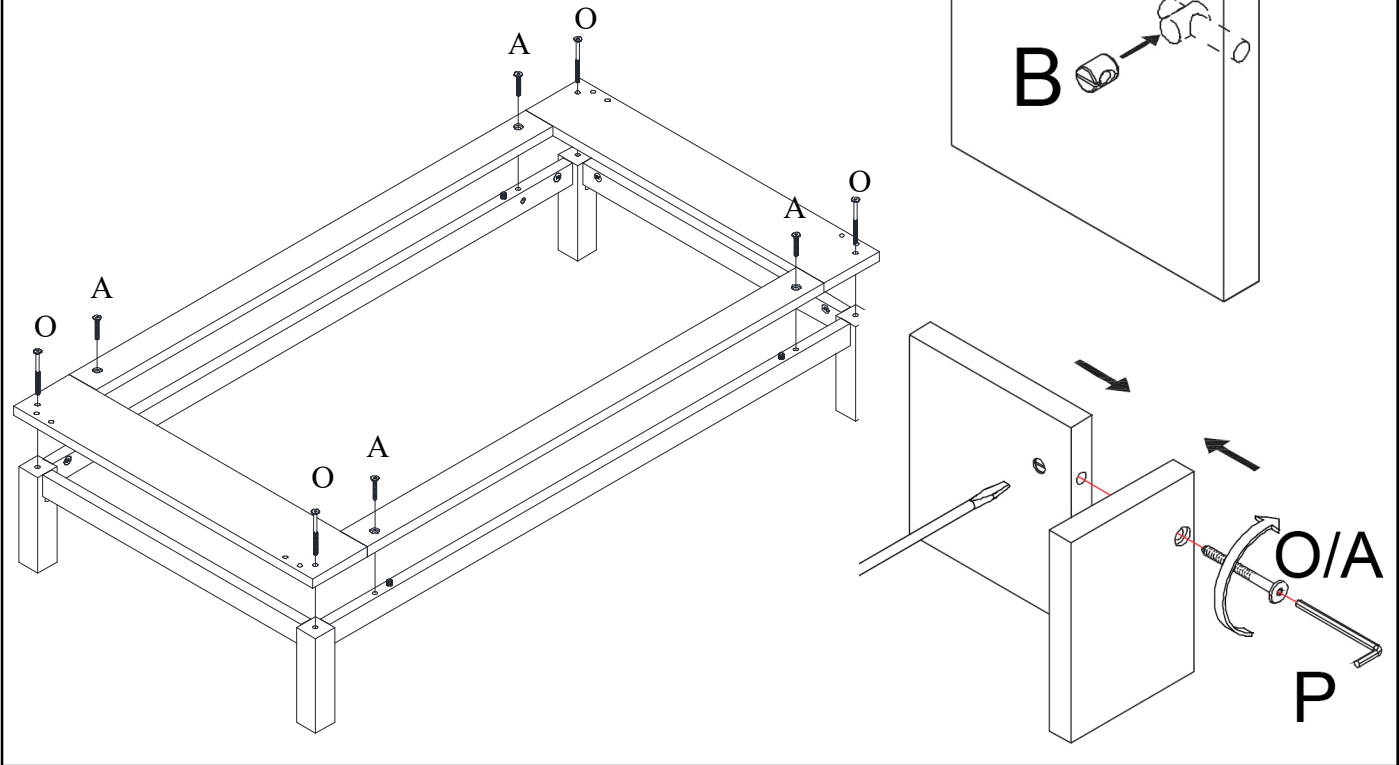
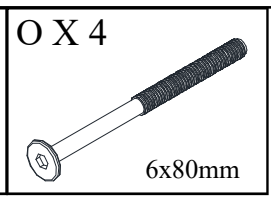
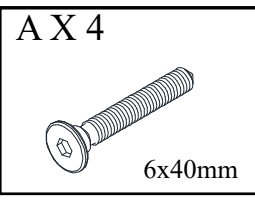

6

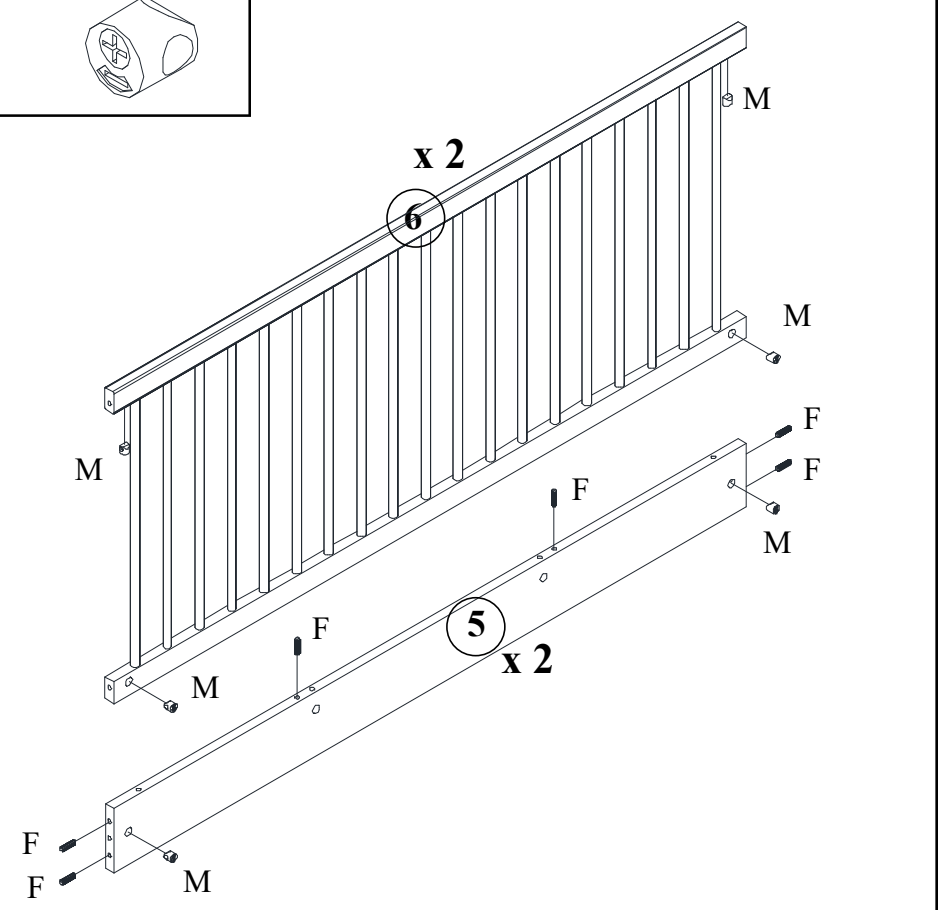
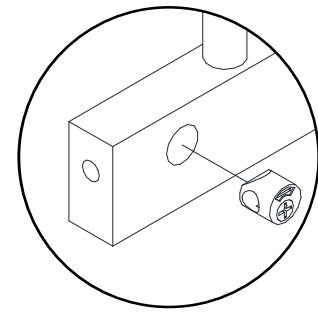
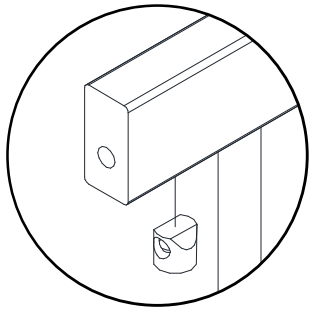
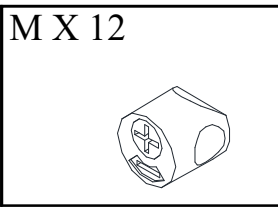
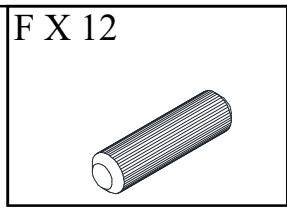

7

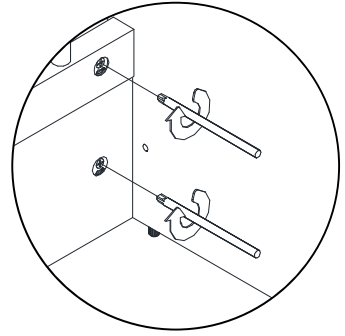
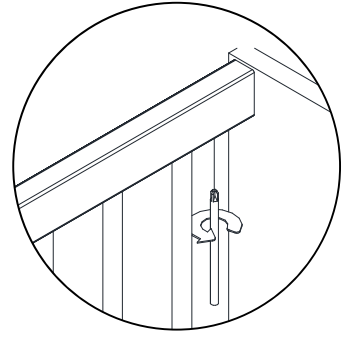
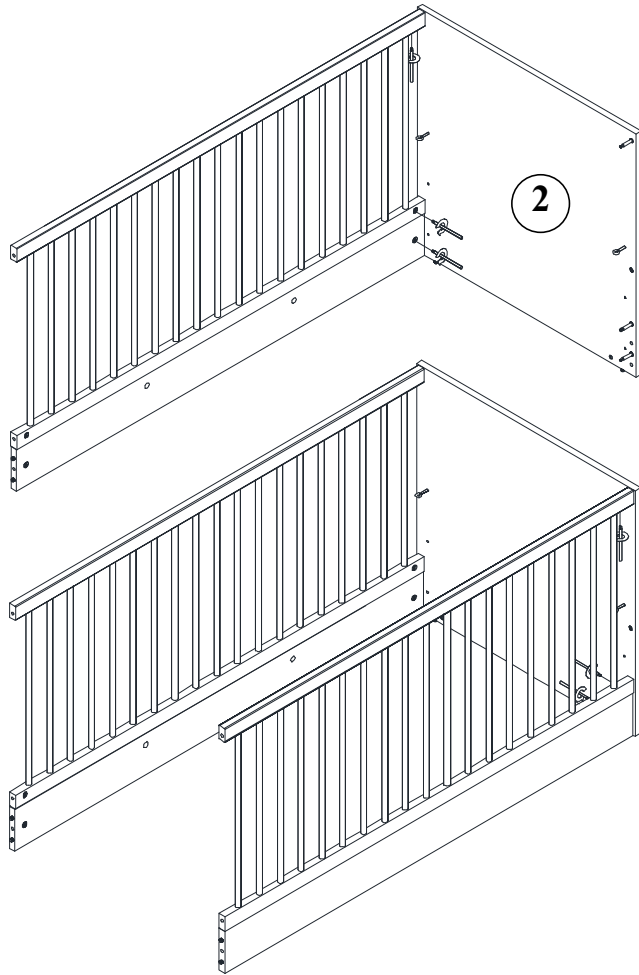

8

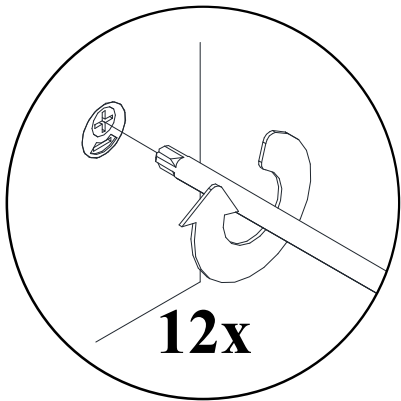
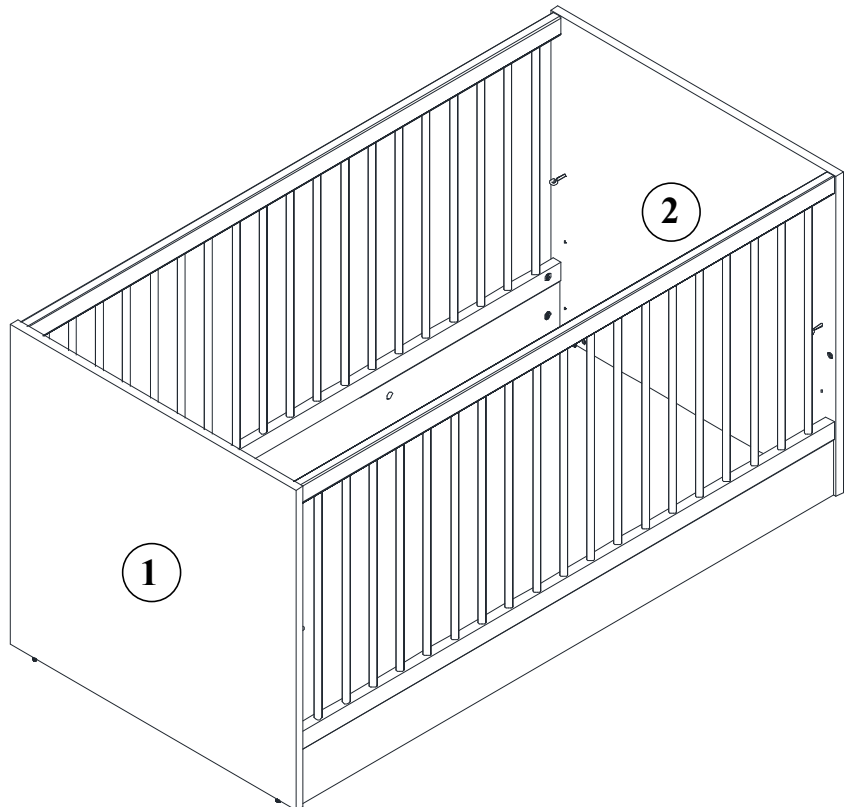

12x

9

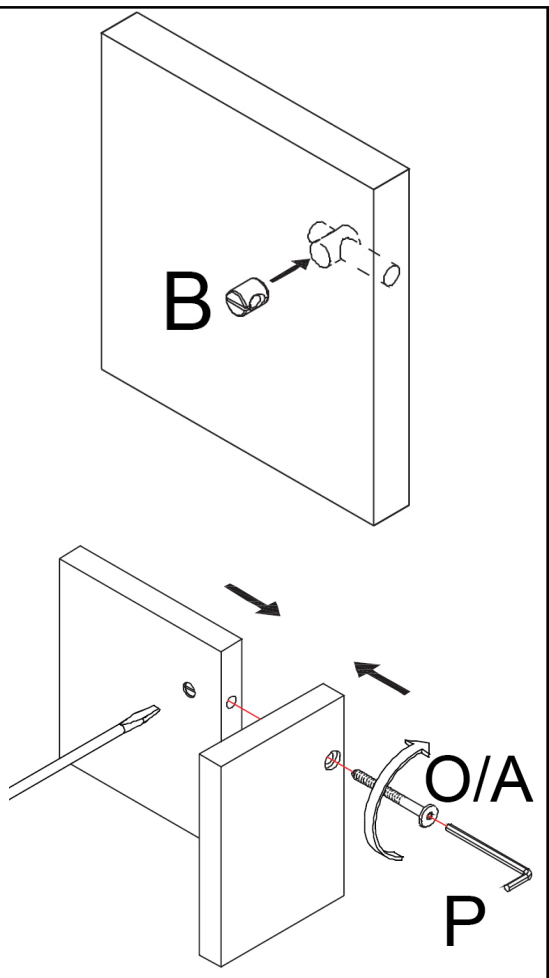
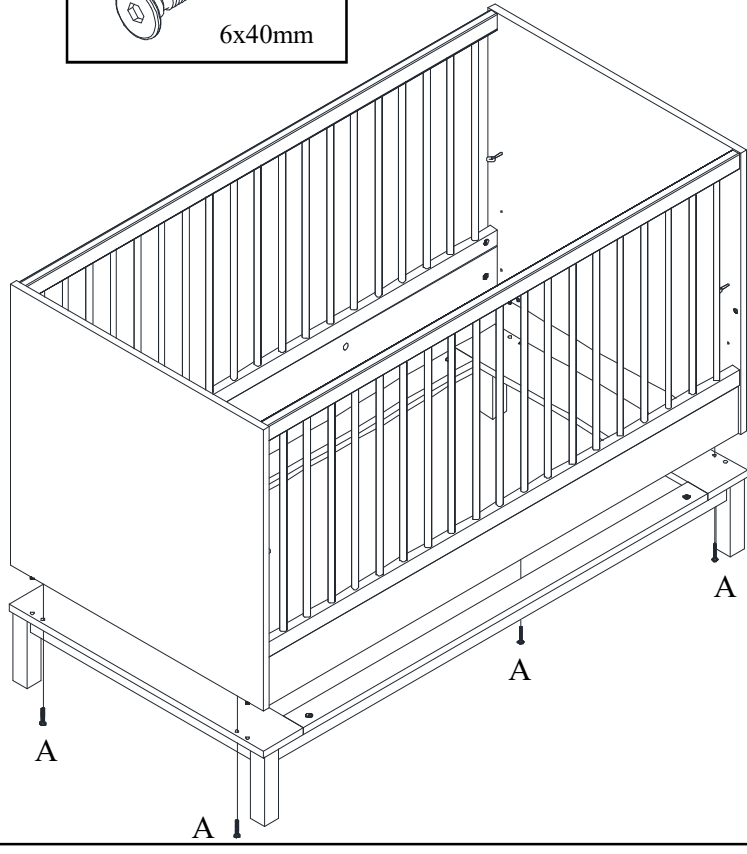
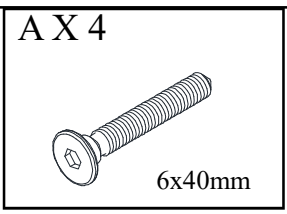

10

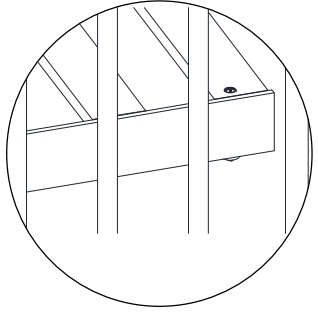
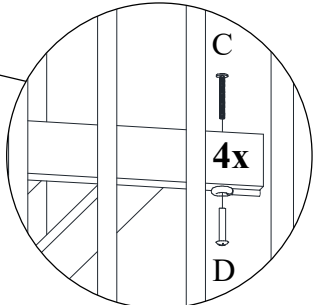
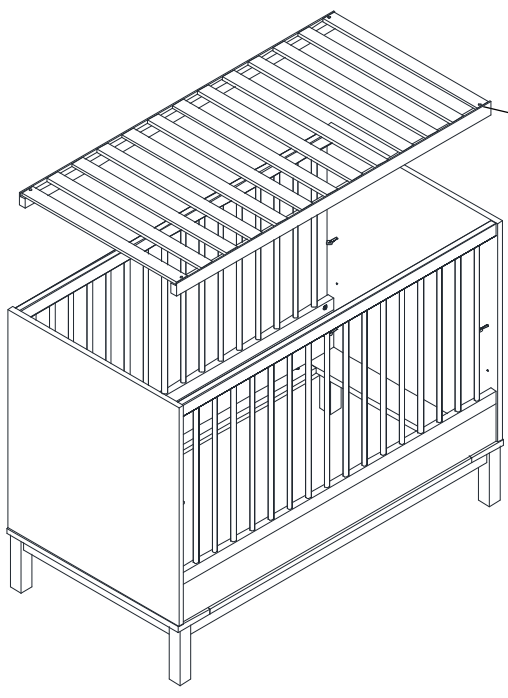
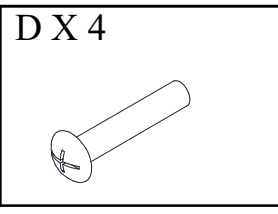
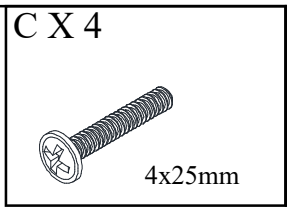

11

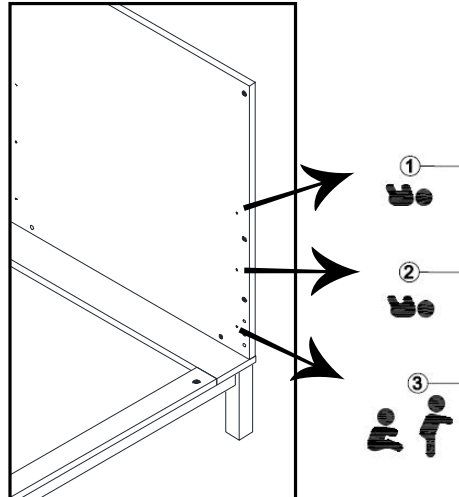
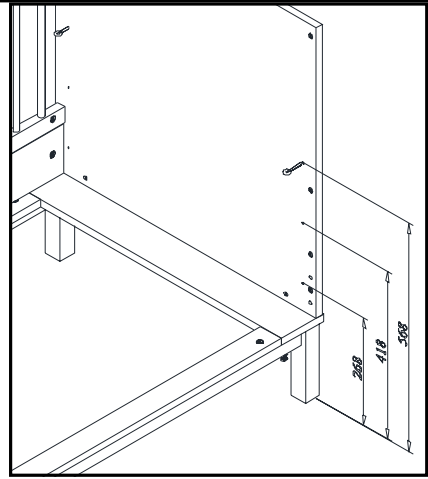
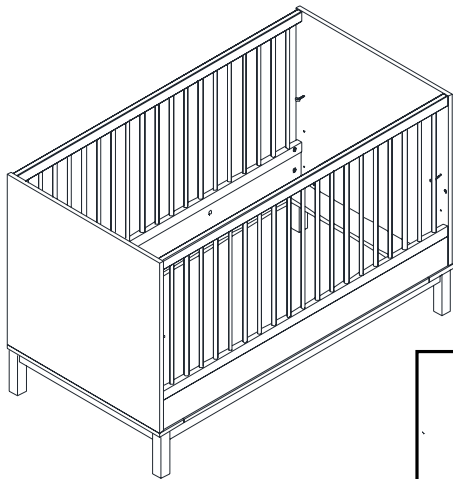

12

B

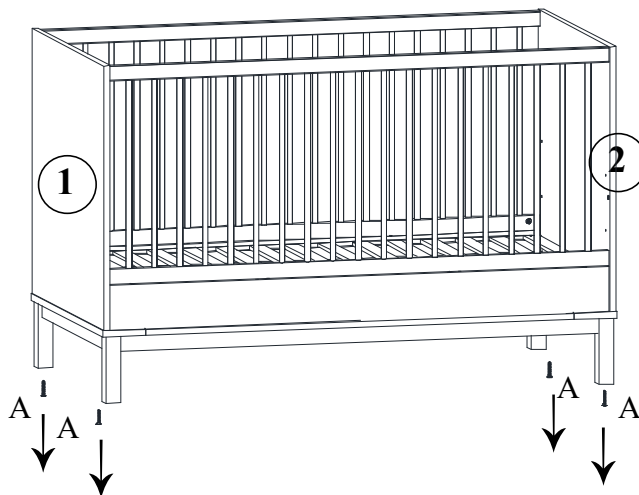
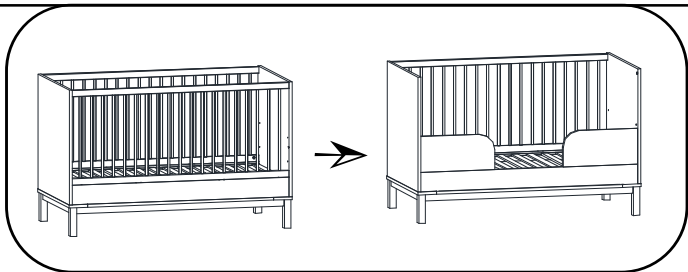

13

B

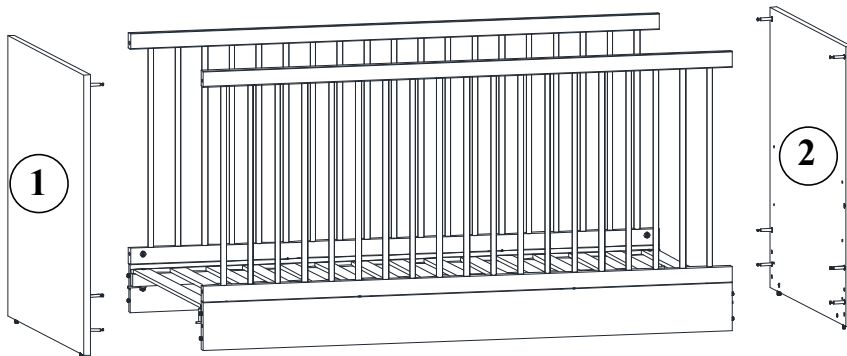

14

B

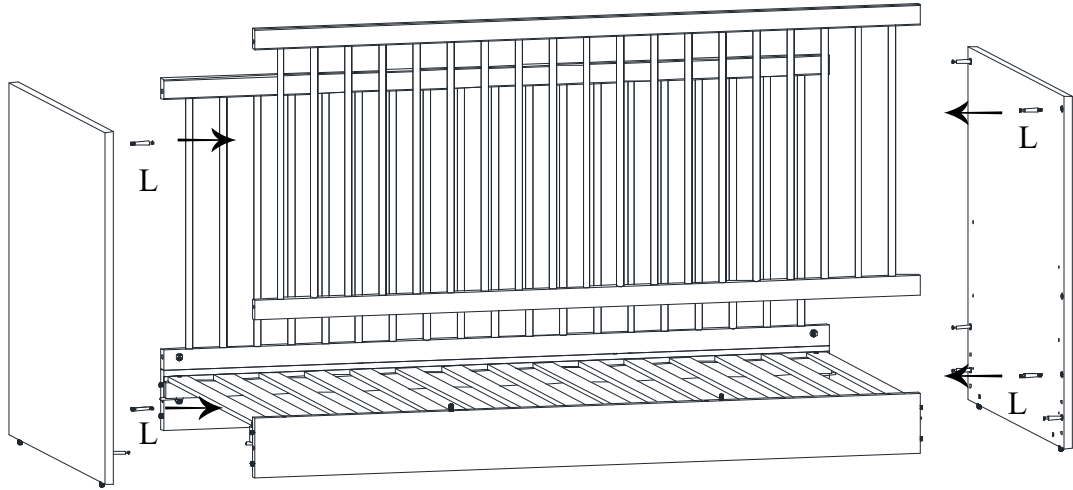

15

B

F X 2

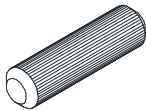

H X 2



K X 2

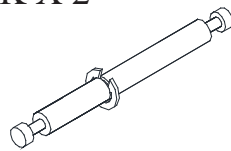

N X 8

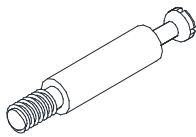

1

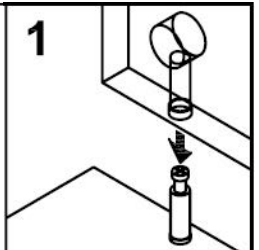

2

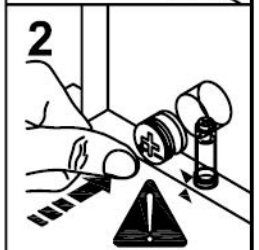

3

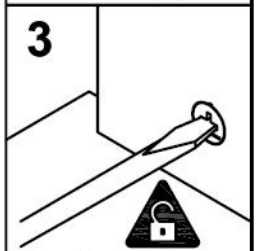

4

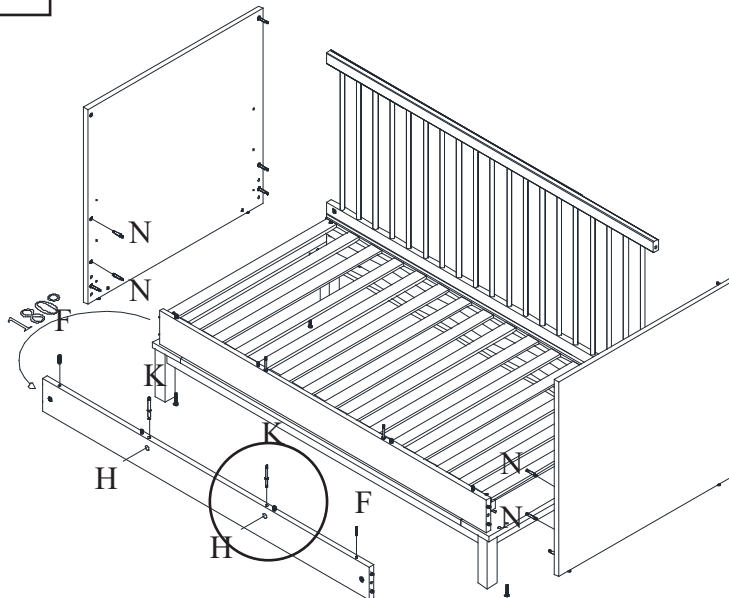
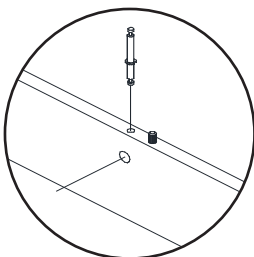
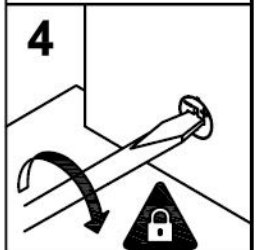

16

B

H X 2

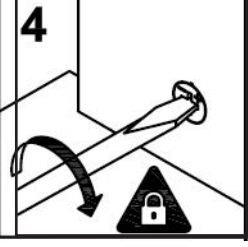
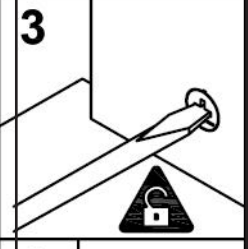
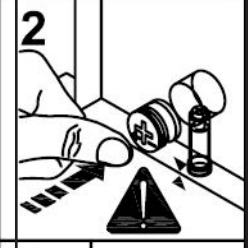
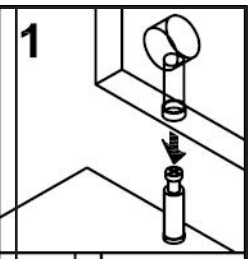
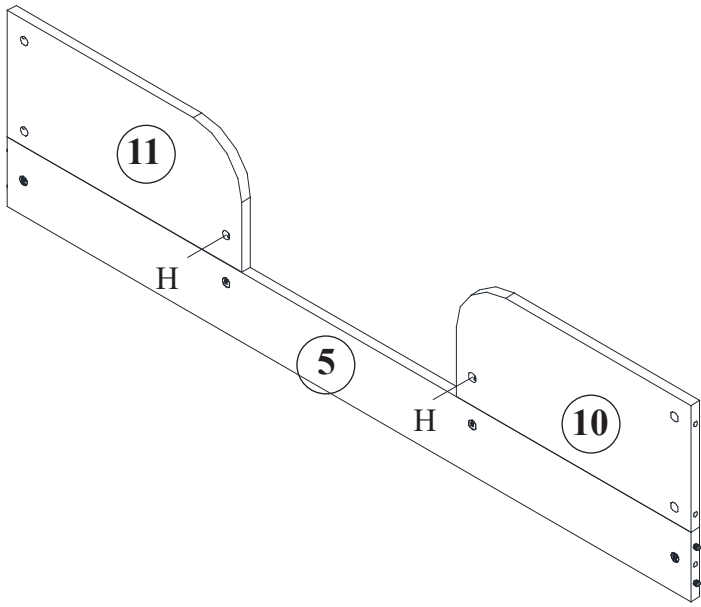

17

B

H X 2

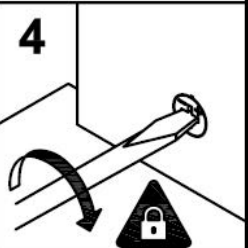
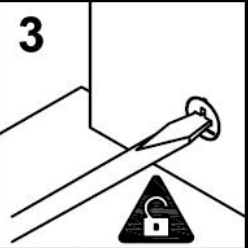
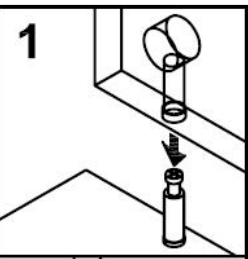
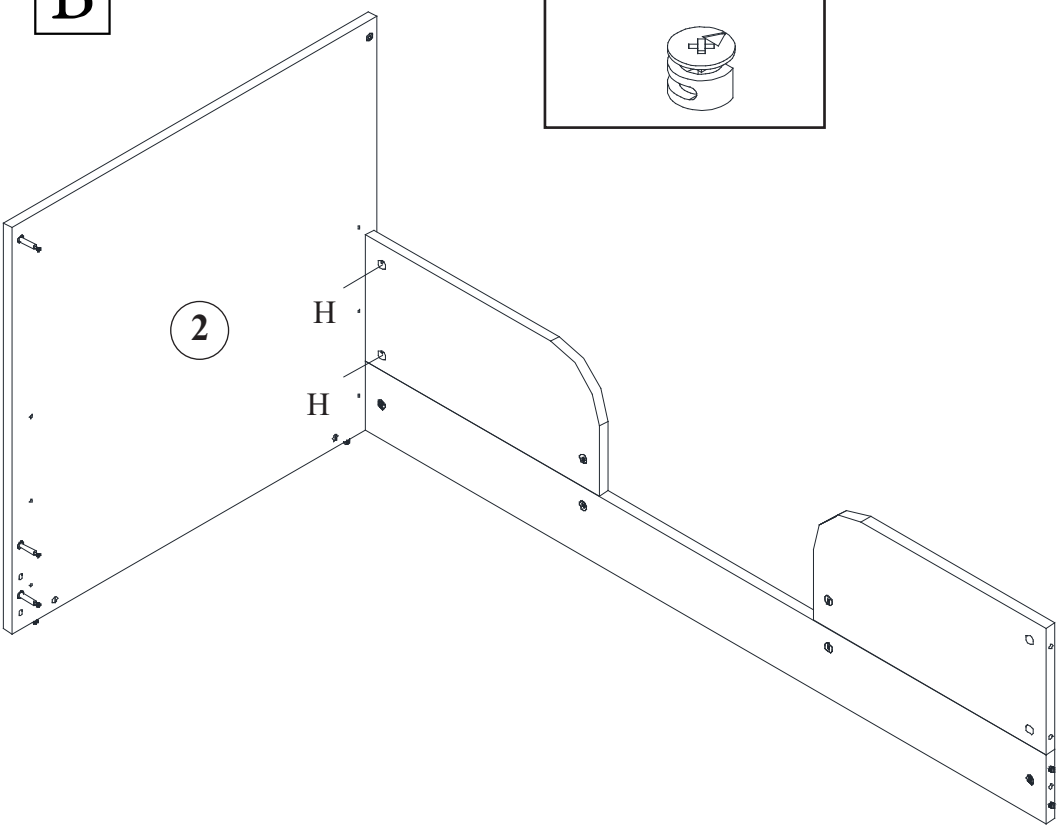

18

B

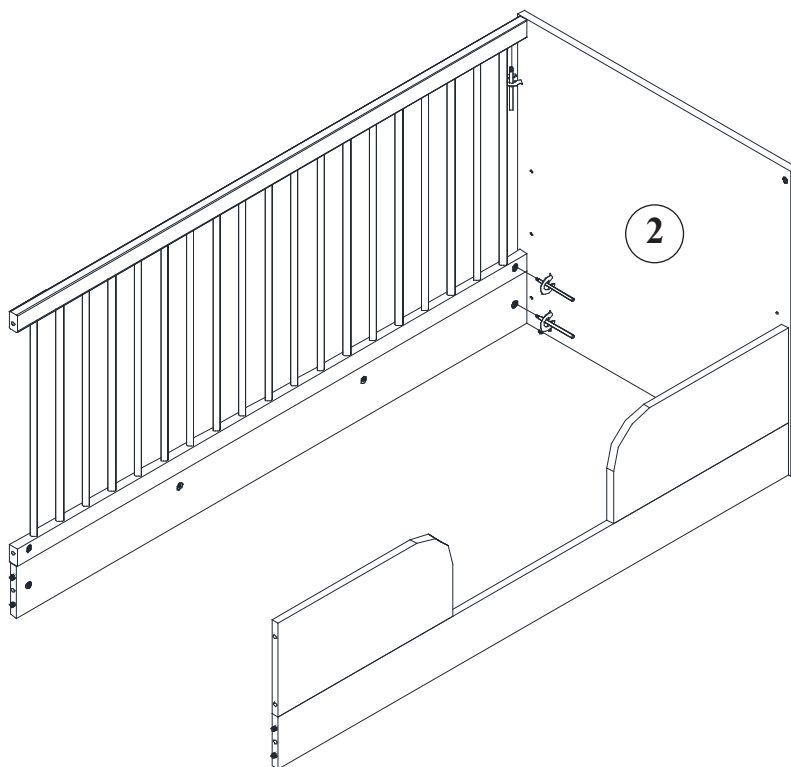
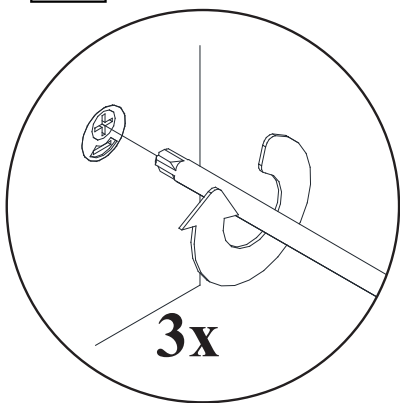

19

B

H X 2

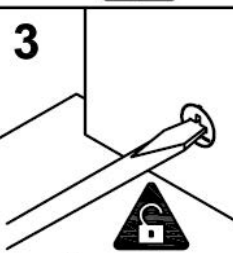
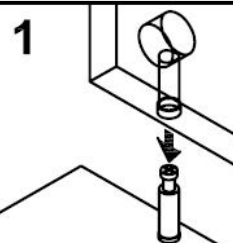
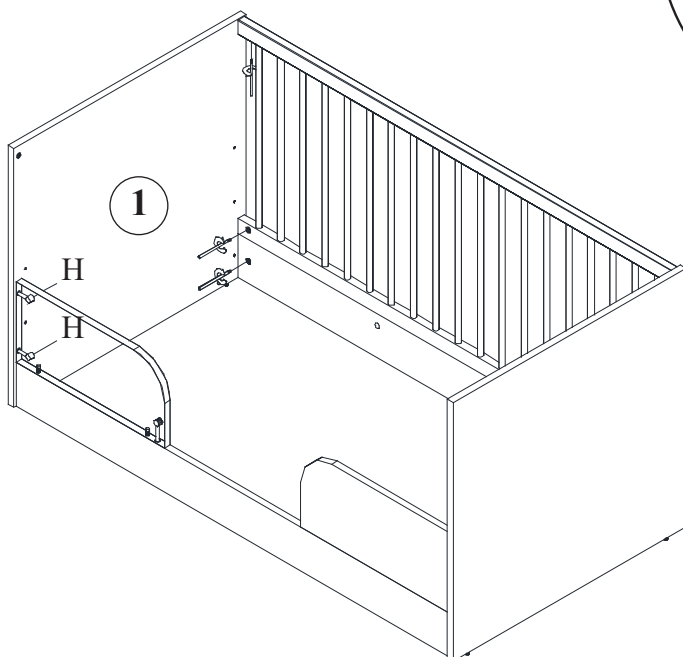
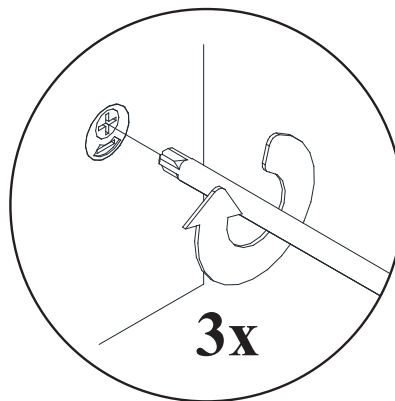

20

B

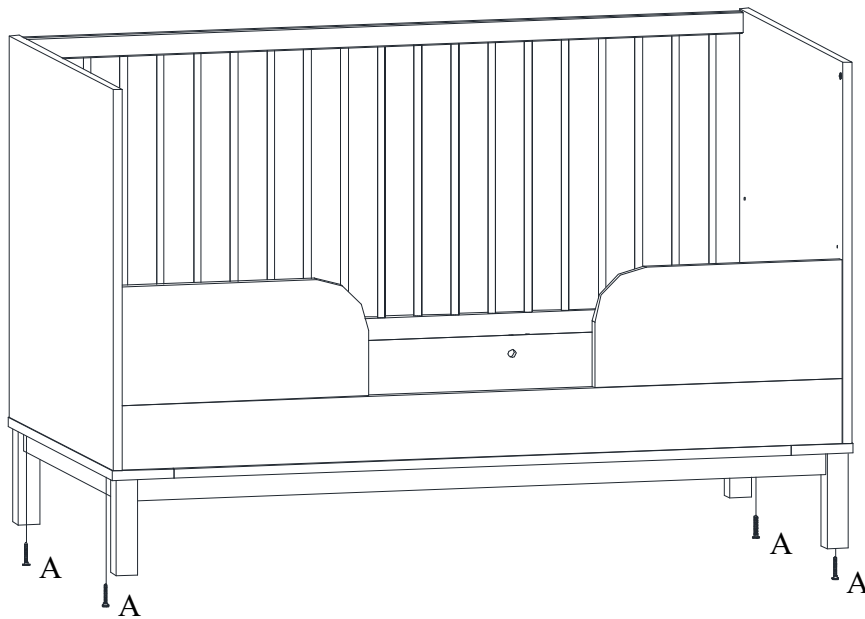

21

B

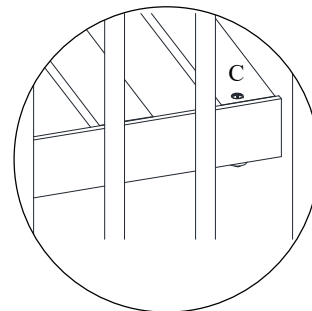
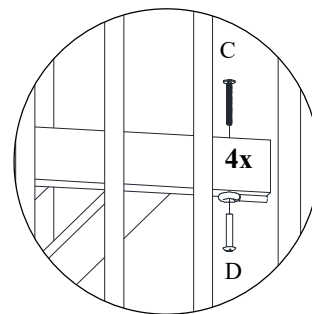
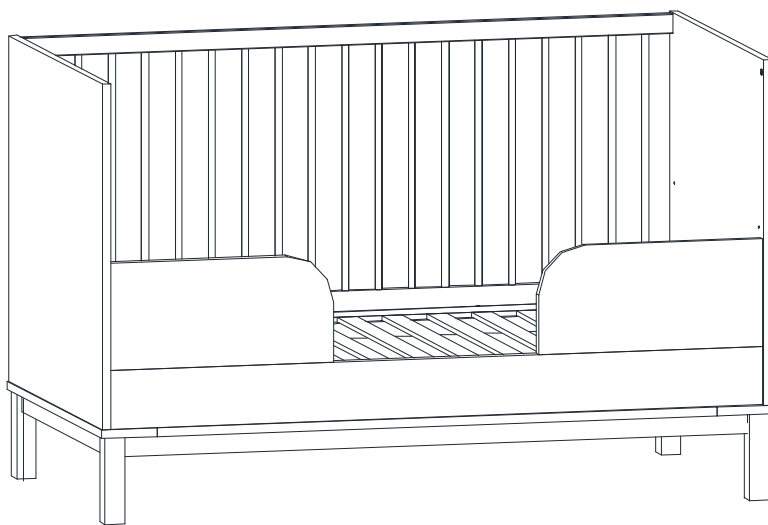

FR - Importé par / EN - Imported by / PT - Importado por / ES - Importado por / DE - Importiert von /
IT - Importato da / NL - Geïmporteerd door :
UE/EU : Vertbaudet SAS - 36 avenue Alfred Lefrançois, 59200 Tourcoing, France
UK: Vertbaudet UK Limited - Elder House, St Georges Business Park, 207 Brooklands Road,
Weybridge, Surrey KT13 0TS

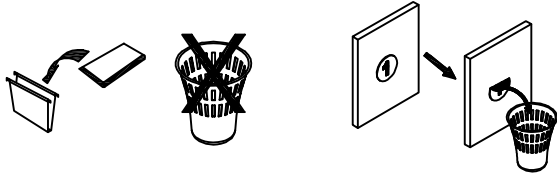

FR - Conserver la clé de montage pour resserrer régulièrement les assemblages afin de donner à votre meuble une stabilité permanente

EN - Keep the assembly spanner to tighten the screws from time to time in order to give permanent stability to your piece of furniture

PT - Conserve a chave de montagem para apertar regularmente as ligações de modo a que o seu movel mantenha uma estabilidade permanente

ES - Conservar la llave de montaje para reforzar regularmente los acoplamientos, con el propósito de ofrecer a su mueble una fijeza permanente.

DE - Den Montageschlüssel aufbewahren, um die Verbindungen regelmässig nachzuziehen, damit Ihr Möbel stabil bleibt

IT - Conservare la chiave di assemblaggio per stringere le viti e garantire la costante stabilità del mobile

NL - De montagesleutel bewaren om de bevestigingen regelmatig vast te draaien. Zo is uw meubel altijd stevig

